

Multifoam 2K

2 Component Fire Protection Foam

European
Technical Assessment
ETA 17/0977



Technical Data Sheet

MULCOL
INTERNATIONAL

Content

Product specification	2
■ Advantages	
■ Applications	
■ Packaging	
1. Technical data	3
2. Acoustic properties	4
3. Components	4
4. Accessories	4
5. Permitted gap dimensions	5
6. General instructions	5
7. Pipe Insulation (Configuration)	5
8. Permitted insulation materials	6
9. Temperature influence on processing Multifoam 2K	6
10. Insulation of non-flammable pipes	7
11. Meter cabinet penetrations	8
12. Performance	9
13. Actually tested solutions	10
14. Minimum spacing between penetrations	11
15. Installation on different surfaces	12
16. Installation with Multifoam Wrap	13
17. Installation with Multifoam Stone	13
18. Installation Manual	14

MULCOL
INTERNATIONAL

Pragmatic, effective
and applicable
solutions



19. Test Configuration	15
20. Building Element Properties	16
21. Available Documents	16
■ Technical documents	
■ Approvals	



Multifoam 2K

2 Component Fire Protection Foam



Fire resistant
≤ 120 minutes



Acoustic insulation
Rw 66 dB



Work life
10 years



Resistant against
Fungi and bacteria

2 Component Fire Protection Foam

Multifoam 2K is a foaming two-component polyurethane foam with fire-retardant additives for the fire-resistant sealing of openings around cable trays, cable bundles, flammable and non-flammable pipes. In the event of fire, the two-component foam prevents fire and smoke from spreading through fire-resistant walls and floors. Multifoam 2K was developed for quick installation and to seal hard-to-reach penetrations.

Multifoam 2K forms part of the Mulcol® Multifoam 2K System. Multifoam 2K can be combined with the Multifoam Wrap in order to realise fire-resistant seals of up to 120 minutes for cable trays, cable ladders, electric cables and cable bundles.

Advantages

- ✓ Fire resistant ≤ 120 minutes
- ✓ CE-certified
- ✓ Installation from one side possible
- ✓ Quick and easy application
- ✓ Efficient processing, no loss of product
- ✓ Permanently elastic and paintable once hardened
- ✓ No trimming required in the case of stucco walls
- ✓ Post-hardening cable mutations possible
- ✓ Excellent adhesion on virtually all surfaces

Applications

- ✓ Rigid walls and floors
- ✓ Flexible walls
- ✓ Plastic pipes up to Ø 50 mm
- ✓ Steel, stainless steel and copper pipes with and without insulation
- ✓ Cable trays, cable ladders, electric cables and cable bundles
- ✓ Aluminium composite pipes with and without insulation
- ✓ Meter box penetrations with encased plastic pipe sleeves

Packaging

	Contents	Box	Pallet	Pallet	Article number
Cartridge	380 ml	6 pieces	60 boxes	360 pieces	301006380

Accessories (included)

- ✓ 12 pieces of mixing nozzles, 380 ml
- ✓ 6 pairs of gloves

1. Technical data

EAN-code	8719324470230
Colour	Red/brown
Shelf life	12 months in unopened packaging at a temperature between 5°C and 30°C
Transportation storage temp.	+5 °C to +30 °C (store dry and dustfree in the original packaging)
Application temperature	+15 °C to +30 °C (optimally +20 °C tot +25 °C)
Temperature resistance	-20 °C to +80 °C
Foam yield*	Up to 2.1 litres (at 22 °C material and ambient temperature)
Work interruption*	Approx. 50 sec.
Cuttability	After approx. 90 seconds (at 22 °C material and ambient temperature)
VOC	< 2 µg/m ³
Density	$\rho \geq 215 \text{ kg/m}^3$
Thermal conductivity (λ)	0,088 W/(m*K)
Expansion pressure	No expansion pressure measurable
Expansion factor ³⁾	1.6 x to 4.5 x
Category of use ¹⁾	Type Z ₁ in accordance with EAD 350454-00-1104
Recoatable ²⁾	Yes
Air permeability	$Q_{600} \leq 0.08 \text{ m}^3/(\text{h}\cdot\text{m}^2)$ (at 600 Pa differential pressure, with measurement accuracy of 0.01 m ³ /h, no air permeability was measurable). Test standard EN 1026 (Tested dimensions: 350 x 350 x 200 mm (lxwxd): EN 1026 (tested without penetrations)
Resistance to static pressure differences	No visible changes up to the maximum test pressure of the test device (P _{max} =10000 Pa). Test standard: In accordance with EN 12211 (sample dimensions 350 x 350 x 200 [mm], tested without penetrations)
Acoustic properties	RW 66 dB (test dimension 360 x 360 x 200 mm)
Fire class	E in accordance with EN 13501-1
Approvals	ETA 17/0977
Function retention	10 years

* Foam output and max. possible work interruptions depend on the material and ambient temperature.

¹⁾ Permissible environmental conditions

Conduit seal for use in conditions with $\geq 85\%$ RH, protected from temperatures below 0 °C, and without exposure to rain and/or UV (TR 024:2009, type Z₁). Limited contact with splash water tolerated. Lasting wetness, stagnant water and water pressure must be avoided.

²⁾ Influence of finishing materials and chemicals

The following paints and occasional brief influences from chemicals will not change the fire protection properties:

Coating materials : Dispersion paint, alkyd paint, polyurethane acrylic paint, epoxy resin paint, silicone

Solvent/oil: : Butyl acetate, butanol, trichloroethylene, xylene, acetone, turpentine

Gaseous chemicals : Brief storage with concentrated ammonium hydroxide solution

Remark

Environmental conditions with high humidity levels and/or some coating materials and chemicals may change the colour or limit colour changes.

³⁾ Expansion factor

Tested on samples at 450 °C for 25 minutes without overload. The expansion factor is a laboratory characteristic value. The expansion factor in an installed state depends on the existing preconditions.

Contact with metals and plastics

The surface consistency of aluminium, stainless steel, galvanised steel and plastics of polyethylene and polyvinyl chloride is not negatively affected by contact with Multifoam 2K and Multifoam Wrap.

2. Acoustic properties

Multifoam 2K has been tested according to EN ISO 717-1, the same or higher sound insulation can be achieved by applying Multifoam 2K over a depth of more than 200 mm. The sound insulation value only applies to the sealant and not to other elements in the building structure.

- ✓ On a test stand with a dimension of 360 x 360 x 200 mm (lxwxh): RW 66 dB

3. Components



Multifoam 2K 380ml, 6 pieces per set
Incl. 12 x Mulcol® Mixing nozzle,
6 pairs of gloves
Packaging unit: 1
Article number: 301006380



Multifoam Stone
(200 x 144 x 60 mm)
Packaging unit: 1
Article number: 303001200



Multifoam Wrap
Incl. 40 steel clips
Packaging unit: 1
Article number: 302001500

4. Accessories



PowerMax dispensing gun
380 ml (5:1)
Packaging unit: 1
Article number: 803010206



HandyMax dispensing gun
380 ml (5:1)
Packaging unit: 1
Article number: 803010202



Mixing nozzle 380 ml
12 pieces per set
Packaging unit: 1
Article number: 803010101



Extension for mixing nozzle
12 pieces per set
Packaging unit: 1
Article number: 803010102



Knife with serrated blade narrow
Packaging unit: 1
Article number: 803010301



Knife with serrated blade wide
Packaging unit: 1
Article number: 803010302



Duct tape
1 roll of 20 meters
Packaging unit: 1
Article number: 803010105



Tempering box
Capacity: 18 pieces of 380 ml
Packaging unit: 1
Article number: 803010401

5. Permitted gap dimensions

The following table shows the maximum gap dimensions based on EN 13501-2. The required injection depth depends on the set fire resistance and the type of penetration, which are further explained in the performance overviews starting on page 8.

Construction	Minimum Thickness [mm]	Multiple penetrations [Cable trays, cables, tubes and pipes]			Single penetrations [Cables and cable ducts]		
		Maximum gap WxH [mm]	Injection depth [mm] *	Classification min. t/m *	Maximum gap WxH [mm]	Injection depth [mm] *	Classification minutes *
Solid walls: Aerated concrete, concrete, reinforced concrete or masonry	≥ 100	450 x 500	≥ 144	≤ EI 60	270 x 270 or Ø 300	≥ 100/144	≤ EI 60
			≥ 200	≤ EI 90		≥ 144/200	≤ EI 90
						≥ 200/250	≤ EI 120
Lightweight partitions: Wooden or steel construction with cladding on both sides	≥ 100	450 x 500	≥ 144	≤ EI 60	270 x 270 or Ø 300	≥ 100/144	≤ EI 60
			≥ 200	≤ EI 90		≥ 144/200	≤ EI 90
						≥ 200/250	≤ EI 120
Solid floors: Aerated concrete, concrete, or reinforced concrete	≥ 150	450 x 450	≥ 144	≤ EI 60	270 x 270 or Ø 300	≥ 100/144	≤ EI 60
			≥ 200	≤ EI 90		≥ 144/200	≤ EI 90
						≥ 200/250	≤ EI 120

* The required injection depth depends on the set fire resistance and the type of penetrations, which are explained in the performance overview.

6. General instructions

A	Cable trays, cables, tubes and pipes must be secured in accordance with the installation instructions.
B	Cable trays and ladders, as well as their supporting elements and attachments must be made of steel and must be present on both sides of the structure. If this is the case, the additional mechanical load must not affect the firestop penetration, even in the event of a fire. The technical regulations of the relevant manufacturer must be observed.
C	Tube and pipe support elements must be made of steel and must be present on both sides of the structure. If this is the case, the additional mechanical load must not affect the firestop penetration, even in the event of a fire. The technical regulations of the relevant manufacturer must be observed.
D	Optionally, cable trays and ladders can be fitted at an angle.
E	The total cross-section (surface) of the penetrations must not exceed 60% of the gap.
F	The first cable tray, cable and pipe supports must be mounted a maximum of 200 mm from the penetration. In the case of floors, this maximum distance is required at the top.
G	In the case of walls, the first pipe support must be installed at a maximum of 750 mm from the penetration. In the case of floors, pipes must be suspended at 1200 mm. This maximum distance is required at the top.

7. Pipe Insulation (Configuration)

Insulations serve different functions and can therefore be arranged around pipes in different manners. This must be taken into account when applying fire stopping seals on these pipes. Possible configurations are shown below:

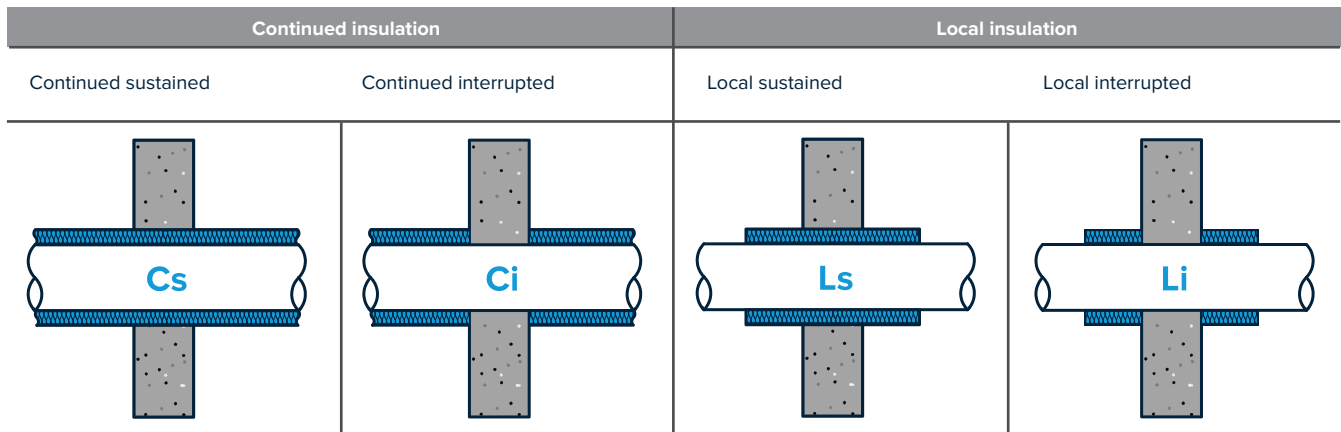

8. Permitted Insulation Materials

Multifoam 2K has been extensively tested with various insulation materials; the table below shows the permitted insulation materials. For principle details, please refer to the Multiselector and our test report: ETA 17/0977

Insulation Type	Tube and pipe types	Permitted ⁽¹⁾
Rock wool insulation <i>Fire class A1,</i> <i>in accordance with EN 13501-1</i>	<ul style="list-style-type: none"> ✓ Copper pipes ✓ Steel pipes (stainless steel) ✓ Cast iron pipes 	<ul style="list-style-type: none"> ✓ Rockwool 810
Elastomer insulation <i>Fire class B_L-s3, d0 or B-s3, d0,</i> <i>in accordance with EN 13501-1</i>	<ul style="list-style-type: none"> ✓ Copper pipes ✓ Steel pipes (stainless steel) ✓ Cast iron pipes 	<ul style="list-style-type: none"> <li style="width: 50%;">✓ AF/Armaflex <li style="width: 50%;">✓ K-Flex EC <li style="width: 50%;">✓ SH/Armaflex <li style="width: 50%;">✓ K-Flex ST <li style="width: 50%;">✓ Kaiflex ST <li style="width: 50%;">✓ K-Flex ST/SK <li style="width: 50%;">✓ Kaiflex KK plus s2 <li style="width: 50%;">✓ K-Flex ST Frigo <li style="width: 50%;">✓ K-Flex EC <li style="width: 50%;">✓ K-Flex SRC <li style="width: 50%;">✓ K-Flex EC AD <li style="width: 50%;">✓ K-Flex SRC Eco
Other thermal insulation <i>Fire class C_L-s1-d0,</i> <i>in accordance with EN 13501-1</i>	<ul style="list-style-type: none"> ✓ Multilayer piping 	<ul style="list-style-type: none"> ✓ PE-Foam o.g.

⁽¹⁾ Insulation materials must have at least the same fire class as tested, in accordance with EN 13501-1.

9. Temperature influence on processing Multifoam 2K foam

Multifoam 2K foam must be processed at a temperature between 15 °C and 30 °C. At a higher temperature the best expansion is achieved, which is approx. 2.5 litres per sleeve at 30 °C. The product also begins to foam more quickly and the foamed and hardened material can be cut off more quickly. Incidentally, the cut-off material can be processed in a subsequent gap so that there is no residual waste.

The temperature box can be used to process the material at the correct temperature. Table 1 shows how the Multifoam 2K foam relates to the temperature.

Table 1

Temperature	[°C]	15 °C	20 °C	30 °C
Theoretical foam yield	[L/sleeve]	1.9	2.0	2.5
Start foaming	[sec.]	ca. 35	ca. 20	ca. 12
Can be cut off after	[sec.]	ca. 110	ca. 90	ca. 70
Work interruption	[sec.]	ca. 70	ca. 50	ca. 40



10. Insulation of non-flammable pipes

Since non-flammable pipes consist of copper, steel, stainless steel and cast steel, in the event of fire, the heat is transported through conduction to the adjacent fire compartment, which must in most cases be insulated. Insulation material is often present around the pipes to prevent heat loss or condensation. The tables below show the minimum insulation length and thickness in the case of rock wool or elastomer insulation. For principle details, please refer to the Multiselector and our test report: ETA 17/0977

Insulated Metal Pipe Penetrations through Flexible Walls, Rigid Walls and Floors

Rock wool insulation, Fire class A₂-s₁, d₀ in accordance with EN 13501-1

Thickness: ≥ 30 mm

Penetrations	Size Ø x s [mm]	Injection depth [mm]	Insulation type	Insulation config. / thickness [mm]	Insulation length [mm]
Non-flammable copper, steel, stainless steel and cast steel pipes are optionally coated with sheet steel or plastic	≤ 28 x 1.0 - 14.2	≥ 144	Optionally without Rock wool	LI/LS - 30 CI/CS - ≥ 30	n.a.
		≥ 200			≥ 428
	≤ 35 x 1.0 - 14.2	≥ 144	Rock wool > 90 kg/m ³		≥ 650
		≥ 200			≥ 428
	≤ 54 x 2.0 - 14.2	≥ 144			≥ 650
		≥ 200			≥ 650

Insulated Metal Pipe Penetrations through Flexible Walls, Rigid Walls and Floors

Elastomeric insulation, Fire class B₁-s₃, d₀ of B-s₃, in accordance with EN 13501-1

Thickness: 9 to 41.5 mm

Penetrations	Size Ø x s [mm]	Injection depth [mm]	Insulation type	Insulation config. / thickness [mm]	Insulation length [mm]
Non-flammable copper, steel, stainless steel and cast steel pipes	≤ 35 x 1.0 - 14.2	≥ 144	Elastomeric insulation	LS/CS - 9 to 35	≥ 500
		≥ 200			
	≤ 42 x 1.5 - 14.2	≥ 144		LS/CS - 9 to 36,5	≥ 500
		≥ 200			
	≤ 54 x 2.0 - 14.2	≥ 144		LS/CS - 9 to 38	≥ 500
		≥ 200			
	≤ 88.9 x 2.0 - 14.2	≥ 144		LS/CS - 41.5	≥ 500
		≥ 200			

Ø x S [mm]:
config./L [mm]:

Diameter x wall thickness of the penetration
Configuration / insulation length

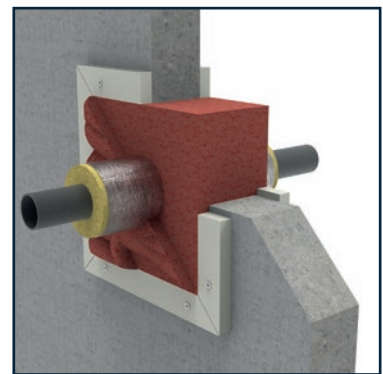
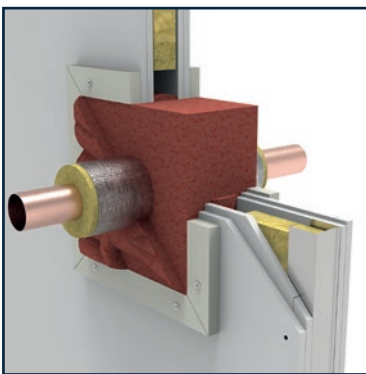

11. Meter cabinet penetrations

Multifoam 2K has been tested according to EN 1366-3 in concrete floors with a thickness of at least 150 mm. Meter cabinet penetrations and openings that are difficult to reach in general can easily be finished on one side with Multifoam 2K foam. The tables below show a few of common penetrations. Refer to the Multiselector for all currently tested solutions with this product.

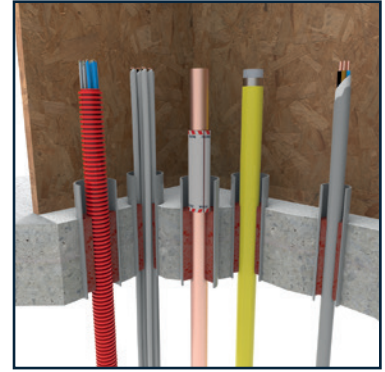

Uninsulated Plastic Pipe Penetrations through Rigid Floors

EN 1366-3

Plastic pipes	Size Ø x s [mm]	Injection depth [mm]	Thickening ⁽²⁾ required [mm]	Insulation config. / L [mm]	Construction RF-150	Classification minutes
PVC-U / PVC-C	≤ 50 x 1.8 - 5.6	≥ 144	n.a.	n.a.	✓	≤ EI 60-U/C
		≥ 200	≥ 2 x 25			≤ EI 120-U/U

Uninsulated Multilayer Pipe Penetrations through Rigid Floors

EN 1366-3

Multilayer pipes ⁽¹⁾	Size Ø x s [mm]	Injection depth [mm]	Thickening ⁽²⁾ required [mm]	Insulation config. / L [mm]	Construction RF-150	Classification minutes
Aluminum composite pipes	≤ 50 x 4.0	≥ 144	n.a.	n.a.	✓	≤ EI 60-U/C

Insulated Multilayer Pipe Penetrations through Rigid Floors

PE-foam insulation, Fire class C_L-s1-d0, in accordance with EN 13501-1

Thickness: ≤ 6 mm

EN 1366-3

Multilayer pipes ⁽¹⁾	Size Ø x s [mm]	Injection depth [mm]	Opdikken ⁽²⁾ vereist [mm]	Insulation config. / L [mm]	Construction RF-150	Classification minutes
Aluminum composite pipes	≤ 32 x 3.0	≥ 144	n.a.	LS, LI-300 or CI, CS	✓	≤ EI 120-U/C

Uninsulated Metal Pipe Penetrations through Rigid Floors

EN 1366-3

Metal pipes	Size Ø x s [mm]	Injection depth [mm]	Thickening ⁽²⁾ required [mm]	Insulation config. / L [mm]	Construction RF-150	Classification minutes
Copper, cast iron and (stainless) steel pipes	≤ 28 x 1.0 - 1.2	≥ 144	n.a.	n.a.	✓	≤ EI 60-C/U
		≥ 200	≥ 2 x 25			≤ EI 90-C/U

Insulated Metal Pipe Penetrations through Rigid Floors

Elastomeric insulation, Fire class B_L-s3, d0 of B-s3, in accordance with EN 13501-1

Thickness: 9 to 41.5 mm

EN 1366-3

Metal pipes	Size Ø x s [mm]	Injection depth [mm]	Thickening ⁽²⁾ required [mm]	Insulation config. / L [mm]	Construction RF-150	Classification minutes
Copper, cast iron and (stainless) steel pipes	≤ 54 x 1.0 - 14.2	≥ 144	n.a.	LS-500 or CS	✓	≤ EI 60-C/U
	≤ 88.9 x 1.0 - 14.2					≤ EI 90-C/U
		≥ 200	≥ 2 x 25			≤ EI 120-C/U

⁽¹⁾ Allowed Multilayer pipes

- Alpex DUO, Valsir Pexal, Valsir Mixal and APE Plain (PE-Xb/AL/PE-Xb)
- Geberit Mepla and Uponor Unipipe (PE-RT/AL/PE-RT)
- Henco and Uponor (PE-Xc/AL/PE-Xc)
- Uponor, REHAU (PE-Xa) en REHAU (PE-Xc)
- SP Superpipe and POLYGON PEX (PE-X/AL/PE-X)
- Valsir Pexal and Valsir Mixal (PE/AL/PE-Xb)
- Wavin Tigris, Protecta-Line System and Alpex F50 Profi (PE-X/AL/PE)

⁽²⁾ Thickening of the construction is only necessary if the required injection depth is not achieved

E: Integrity
I: Thermal insulation

RF-150: Rigid floor, 150 mm thick

Ø x S [mm]: Diameter x wall thickness of the penetration
config./L [mm]: Configuration / insulation length

12. Performance

Uninsulated Plastic Pipe Penetrations through Flexible Walls, Rigid Walls and Floors

EN 1366-3

Plastic pipes	Size Ø x s [mm]	Injection depth [mm]	Thickening ⁽²⁾ required [mm]	Insulation config. / L [mm]	Construction			Classification minutes
					FW-100	RW-100	RF-150	
PVC-U / PVC-C	≤ 50 x 1.8 - 5.6	≥ 144	≥ 2 x 25	n.a.	✓	✓		≤ EI 120-U/C
			n.a.				✓	≤ EI 60-U/C
		≥ 200	≥ 4 x 25		✓	✓		≤ EI 120-U/U
			≥ 2 x 25				✓	≤ EI 120-U/U
PE / PE-HD / ABS / SAN+PVC	≤ 50 x 2.9 - 5.6	≥ 144	≥ 2 x 25	n.a.	✓	✓		≤ EI 120-U/C
			n.v.t.				✓	≤ EI 60-U/C
		≥ 200	≥ 4 x 25		✓	✓		≤ EI 120-U/U
			≥ 2 x 25				✓	≤ EI 120-U/U

Uninsulated Multilayer Pipe Penetrations through Flexible Walls, Rigid Walls and Floors

EN 1366-3

Multilayer pipes ⁽¹⁾	Size Ø x s [mm]	Injection depth [mm]	Thickening ⁽²⁾ required [mm]	Insulation config. / L [mm]	Construction			Classification minutes
					FW-100	RW-100	RF-150	
Aluminum composite pipes	≤ 32 x 3.0	≥ 144	≥ 2 x 25	n.a.	✓	✓		≤ EI 90-U/C
	≤ 50 x 4.0		n.a.				✓	≤ EI 60-U/C

Insulated Multilayer Pipe Penetrations through Flexible Walls, Rigid Walls and Floors Elastomeric insulation, Fire class B_L-s3, d0 of B-s3, in accordance with EN 13501-1 Thickness: 25 mm

EN 1366-3

Multilayer pipes ⁽¹⁾	Size Ø x s [mm]	Injection depth [mm]	Thickening ⁽²⁾ required [mm]	Insulation config. / L [mm]	Construction			Classification minutes
					FW-100	RW-100	RF-150	
Aluminum composite pipes	≤ 75 x 6.0	≥ 144	≥ 2 x 25	LS, LI - 300 or CI, CS	✓	✓		≤ EI 120-U/C
			n.a.				✓	

Insulated Multilayer Pipe Penetrations through Flexible Walls, Rigid Walls and Floors PE-foam insulation, Fire class C_L-s1-d0, in accordance with EN 13501-1 Thickness: ≤ 6 mm

EN 1366-3

Multilayer pipes ⁽¹⁾	Size Ø x s [mm]	Injection depth [mm]	Thickening ⁽²⁾ required [mm]	Insulation config. / L [mm]	Construction			Classification minutes
					FW-100	RW-100	RF-150	
Aluminum composite pipes	≤ 32 x 3.0	≥ 144	≥ 2 x 25	LS, LI - 300 or CI, CS	✓	✓		≤ EI 120-U/C
			n.a.				✓	

⁽¹⁾ Allowed Multilayer pipes

- Alpex DUO, Valsir Pexal, Valsir Mixal and APE Plain (PE-Xb/AL/PE-Xb)
- Geberit Mepla and Uponor Unipipe (PE-RT/AL/PE-RT)
- Henco and Uponor (PE-Xc/AL/PE-Xc)
- Uponor, REHAU (PE-Xa) and REHAU (PE-Xc)
- SP Superpipe and POLYGON PEX (PE-X/AL/PE-X)
- Valsir Pexal and Valsir Mixal (PE/AL/PE-Xb)
- Wavin Tigris, Protecta-Line System and Alpex F50 Profi (PE-X/AL/PE)

⁽²⁾ Thickening of the construction is only necessary if the required injection depth is not achieved

E: Integrity
I: Thermal insulation

FW-100: Flexible wall, 100 mm thick
RW-100: Rigid wall, 100 mm thick
RW-150: Rigid wall, 150 mm thick

Ø x S [mm]: Diameter x wall thickness of the penetration
config./L [mm]: Configuration / insulation length

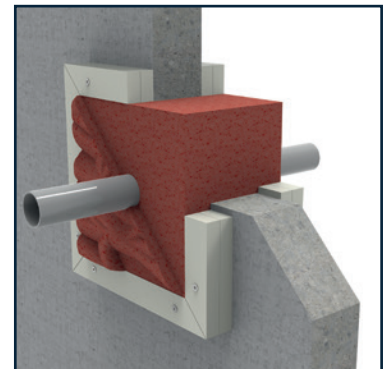
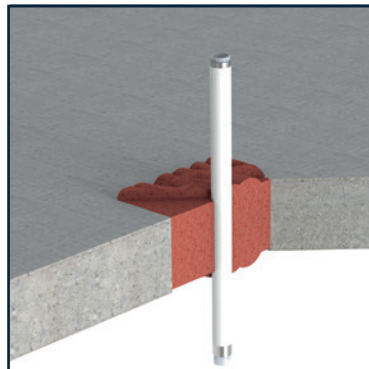

Uninsulated Metal Pipe Penetrations through Flexible Walls, Rigid Walls and Floors

EN 1366-3

Metal pipes	Size Ø x s [mm]	Injection depth [mm]	Thickening ⁽²⁾ required [mm]	Insulation config. / L [mm]	Construction			Classification minutes
					FW-100	RW-100	RF-150	
Copper, cast iron and (stainless) steel pipes	≤ 28 x 1.0 - 14.2	≥ 144	≥ 2 x 25	n.a.	✓	✓		≤ EI 60-C/U
			n.a.				✓	≤ EI 60-C/U
		≥ 200	≥ 4 x 25		✓	✓		≤ EI 90-C/U
			≥ 2 x 25				✓	≤ EI 90-C/U

**Insulated Metal Pipe Penetrations through Flexible Walls, Rigid Walls and Floors
Elastomeric insulation, Fire class B₁-s3, d0 of B-s3, in accordance with EN 13501-1
Thickness: 9 to 41.5 mm**

EN 1366-3

Metal pipes	Size Ø x s [mm]	Injection depth [mm]	Thickening ⁽²⁾ required [mm]	Insulation config. / L [mm]	Construction			Classification minutes
					FW-100	RW-100	RF-150	
Copper pipes	≤ 54 x 1.0 - 14.2	≥ 144	≥ 2 x 25	LS - 500 or CS	✓	✓		≤ EI 90-C/U
			n.a.				✓	≤ EI 60-C/U
Cast iron and (stainless) steel pipes	≤ 88.9 x 1.0 - 14.2	≥ 144	≥ 2 x 25		✓	✓		≤ EI 90-C/U
			n.a.				✓	≤ EI 60-C/U
		≥ 200	≥ 4 x 25		✓	✓		≤ EI 120-C/U
			≥ 2 x 25				✓	≤ EI 120-C/U

Cable Trays ≤ 500 mm through Flexible Walls, Rigid Walls and Floors

EN 1366-3

Cable trays ≤ 500 mm	Size Ø x s [mm]	Injection depth [mm]	Thickening ⁽²⁾ required [mm]	Insulation config. / L [mm]	Construction			Classification minutes
					FW-100	RW-100	RF-150	
Provided with: Electric cables ≤ Ø 50 mm, max. bundled up to Ø 80 mm and electric cables ≤ Ø 21 mm, max. bundled up to ≤ Ø 100 mm	≤ 270 x 270 or ≤ Ø 300	≥ 144	≥ 2 x 25	n.a.	✓	✓		≤ EI 60
			n.a.				✓	≤ EI 60
Provided with: Electric cables ≤ Ø 21 mm, max. bundled up to Ø 100 mm and electric cables ≤ Ø 80	450 x 500	≥ 200	≥ 4 x 25		✓	✓		≤ EI 90
	450 x 500		≥ 2 x 25				✓	≤ EI 90
		≥ 144	n.v.t.				✓	≤ EI 60
								✓

⁽¹⁾ Allowed Multilayer pipes
 - Alpex DUO, Valsir Pexal, Valsir Mixal and APE Plain (PE-Xb/AL/PE-Xb)
 - Geberit Mepla and Uponor Unipipe (PE-RT/AL/PE-RT)
 - Henco and Uponor (PE-Xc/AL/PE-Xc)
 - Uponor, REHAU (PE-Xa) and REHAU (PE-Xc)
 - SP Superpipe and POLYGON PEX (PE-X/AL/PE-X)
 - Valsir Pexal and Valsir Mixal (PE/AL/PE-Xb)
 - Wavin Tigris, Protecta-Line System and Alpex F50 Profi (PE-X/AL/PE)

⁽²⁾ Thickening of the construction is only necessary if the required injection depth is not achieved

E: Integrity
 I: Thermal insulation

FW-100: Flexible wall, 100 mm thick
 RW-100: Rigid wall, 100 mm thick
 RW-150: Rigid wall, 150 mm thick

Ø x S [mm]: Diameter x wall thickness of the penetration
 config./L [mm]: Configuration / insulation length

13. Actually tested solutions

All the latest tested solutions with the Multifoam 2K can be found in our **Multiselector**. Scan the QR code or press the Multiselector button to get directly to the tested solution for your project.



Our **Multiselector** can also be found in our **Mulcol Fire Protection App**. It can be downloaded from the **App Store** (iOS) or **Google Play Store** (Android).



14. Minimum spacing between penetrations

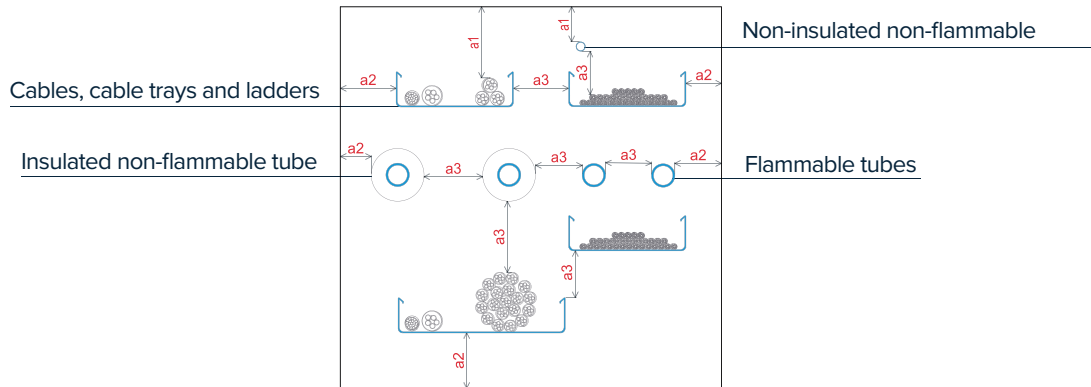

Legend

- a1: Distance from penetration to top of gap
- a2: Distance from penetration to bottom of gap
- a3: Distance between penetrations

Minimum spacing between multiple penetrations				
Penetration	a1	a2	a3	
Cables, cable trays, ladders and tubes	50 mm	0 mm	Cables/cable trays, ladders and tubes, horizontal	0 mm
			Cables/cable trays, ladders and tubes, vertical	50 mm
			Non-insulated non-flammable pipes	60 mm
			Other penetrations	50 mm
Non-flammable pipes with rock wool insulation	0 mm	0 mm	Non-flammable pipes with rock wool insulation	0 mm
			Non-insulated non-flammable pipes	60 mm
			Other penetrations	50 mm
Non-flammable pipes with Elastomer insulation	35 mm	35 mm	Non-flammable pipes with Elastomer insulation (thickness > 9 mm)	35 mm
			Non-flammable pipes with Elastomer insulation (thickness > 9 mm)	50 mm
			Non-insulated non-flammable pipes	60 mm
			Other penetrations	50 mm
Non-insulated non-flammable pipes	35 mm	35 mm	Non-insulated non-flammable pipes	60 mm
			Other penetrations	60 mm
Flammable pipes	50 mm	50 mm	Flammable pipes	50 mm
			Non-insulated non-flammable pipes	60 mm
			Other penetrations	50 mm
Minimum spacing between gaps (for both walls and floors)				100 mm

Minimum spacing between cable penetrations				
Penetration	a1	a2	a3	
Cables, cable trays, ladders and tubes	50 mm	0 mm	Cables/cable trays, ladders and tubes	0 mm
Minimum spacing between gaps (for both walls and floors)				100 mm

15. Installation on different surfaces

If the thickness of the construction is insufficient to inject Multifoam 2K over the minimum tested depth, it must be thickened. This applies for lightweight partition walls, solid walls and floors. Below are a few points of interest that apply to the various structures.

1. Installation in solid walls and floors

- A** If the thickness of the solid wall or floor at the penetrations is less than the required minimum injection depth, cladding (see Fig. 3) or frame (see Fig. 1 & 2) of flammable gypsum boards, silicate or calcium silicate boards (class A2-s1, d0 or A1 according to EN 13501-1) must be fitted in the seals on the construction. This allows the Multifoam 2K to be injected over the minimum required injection depth.

- B** When installing cladding in the gap, the minimum panel thickness must be at least 2 x 12.5 mm or 25 mm. The panels are clamped together in the gap, any seams and cracks between the solid construction and the cladding should be sealed with Multimortar or Multimastic SP mastic, for example. In the case of walls, attachment with screws is not necessary.

- C** To attach the plate frame (min. 50 mm wide and max. 50 mm thick) on walls and floors, use metal fasteners that are large/long enough and suitable for the surface. In the case of aerated concrete, chipboard screws should be used without plugs. At least two screws must be used per sheet; the distance between the screws must not exceed 250 mm.

- D** In the case of solid floors, the Multifoam 2K system must be protected against loads, in particular against entering the floor through a grille or a casing

2. Installation in lightweight partitions

- A** If the thickness of the lightweight partition at the penetrations is less than the required minimum injection depth, a cladding (see Fig. 3) or frame (see Fig. 1 & 2) of flammable gypsum boards, silicate or calcium silicate boards (class A2-s1, d0 or A1 according to EN 13501-1) must be fitted in the seals on the construction. This allows the Multifoam 2K to be injected over the minimum required injection depth.

- B** For openings up to a size of 320 x 320 mm, a trimming joint of steel profiles can be omitted. For larger openings, a steel profile is sufficient at the underside and top of the gap, which must be fixed in the same way as prescribed for the wall cladding. A connection to the vertical steel profiles in the wall is not necessary.

- C** When installing cladding in the recess, the minimum panel thickness must be at least 2 x 12.5 mm or 25 mm. The boards are clamped together in the gap, any seams and cracks between the light partition and the cladding should be sealed with Multimortar or Multimastic SP mastic, for instance. Attachment with screws is not necessary.

- D** To attach the plate frame (min. 50 mm wide and max. 50 mm thick) on walls, use metal fasteners that are large enough / long enough and suitable for the surface. Two screws must be used per sheet; the distance between the screws must not exceed 250 mm.

- E** If no frame is used, the cavity between the cladding of the flexible wall should be closed - with mineral wool (melting point ≥ 1000 °C, minimum density 40 kg/m³) of at least 100 mm around the recess.

- F** In the case of lightweight partitions with wooden posts, a distance of at least 100 mm must be maintained between the penetrations and the wooden posts. The spacing must be filled with mineral wool (class A2-s1, d0 or A1) in accordance with EN 13501-1.

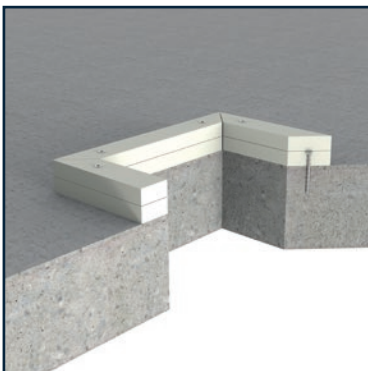

Fig. 1
Frame for solid floors (1- or 2-sided mounted, thickness max. 50 mm per side)

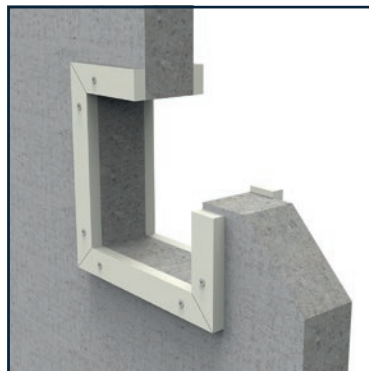

Fig. 2
Frame for solid and light walls (1- or 2-sided mounted, thickness max. 50 mm per side)

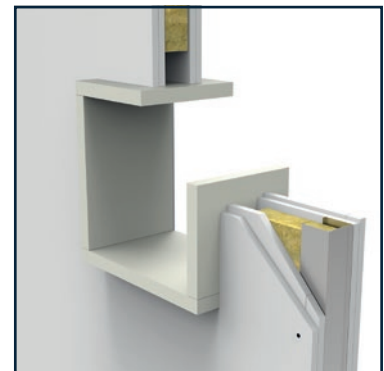

Fig. 3
Frame for solid and light walls (Centred in the recess with floors it may penetrate on one side)



16. Installation with Multifoam Wrap

For cable trays that must comply with EI 120 minutes, it is in some cases necessary to mount the Multifoam Wrap on both sides of the structure around electric cables and cable trays. Below is a description of the installation method

1. The Multifoam Wrap must be cut at a sufficient length, after which the white protective film must be removed.
2. One layer of Multifoam Wrap (150 mm wide) should be wrapped around the penetration(s) on both sides of the structure. The adhesive side must rest on the cables or cable trays. The fibreglass fabric that serves as protection is on the outside.
3. The beginning and end of the Multifoam Wrap must be connected with at least two steel clips or steel wire (\varnothing 1 mm). The overlap length must be at least 45 mm.
4. Multiple strips can also be placed one after the other with an overlap of at least 45 mm. The butt joints must also be connected with steel clips or a steel wire.

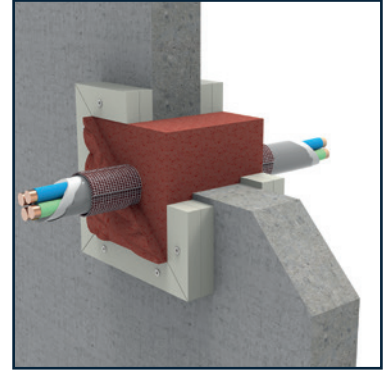
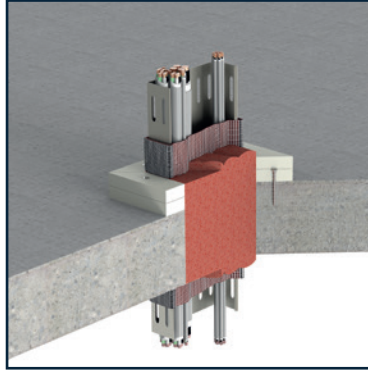
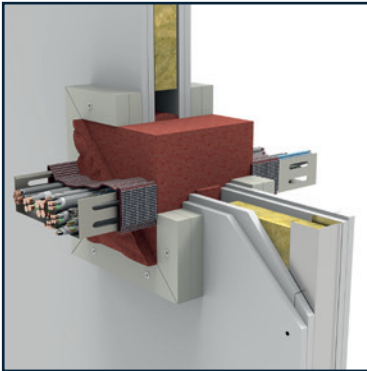

17. Installation with Multifoam Stone

Gaps in lightweight partitions, solid walls and floors can be sealed completely fire-resistant in a simple manner with Multifoam 2K foam. This product can also be installed in combination with Multifoam Stone. In this case, the areas that are not penetrated by cables, cable trays, pipes or tubes can be sealed with Multifoam Stone. Maintain the minimum seal thickness during installation. Below is a description of the installation method.

1. The protective film must be removed from the Multifoam Stone.
2. Install the Multifoam Stone in layers (i.e. in "half brick formation") so that they fit tightly into the opening.
3. Seal other openings, seams and cracks with Multifoam 2K foam.

For detailed installation instructions, refer to the Multifoam Stone installation instructions.

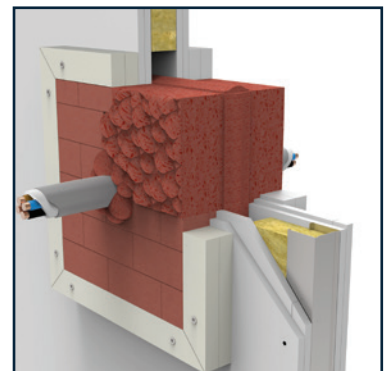
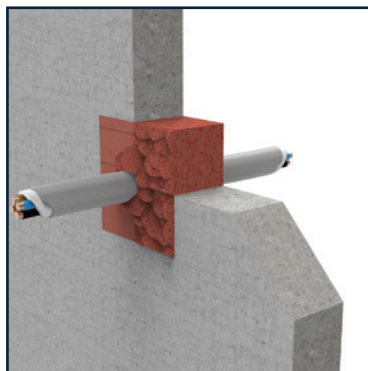
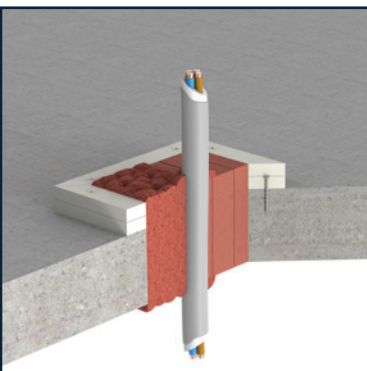

18. Installation Manual

1

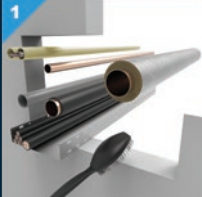

Make sure that the service penetrations and the gap are free from dust, dirt and grease. If necessary, the other side of the opening can be sealed with cardboard, plastic film or form tape.

5

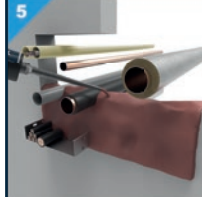

Fill the opening from the back to the front and build the foam from bottom to the top. Always keep the end of the mixing nozzle above the foam so that it does not become clogged 1).

2



Hold the cartridge vertically with the cap facing upwards, unscrew the cap and mount the supplied mixing nozzle.

6

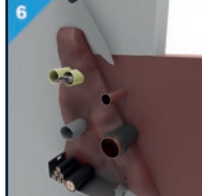

After about 2 minutes the protruding foam residue can be cut off with a suitable knife.

3



Place the cartridge in the holder of a sealant gun.

7



Fill in the conformity statement and paste it next to the fireproof seal.

4



Hold the sealant gun upwards so that the two components come out of the mixing nozzle simultaneously. Discard the first material to come out that is not mixed.

8



After the Multifoam 2K has been installed, cable changes can be carried out carefully without damaging the fireproof seal!

¹⁾ After a work interruption of longer than about 50 seconds, the foam in the mixing nozzle heats up and it must be replaced. Remove pressure from the sealant gun before replacing the mixing nozzle and remove it carefully.

PowerMax Settings

The recommendations below are based on experience and are for guidance purposes only. The user is solely responsible for adjusting the settings to current conditions and for using the equipment with the necessary caution. It is essential that you do not continue to inject if the mixing nozzle is clogged up. First replace the mixing nozzle, and slowly heat up the cartridge if it is too cold.

At application temperature (+15 to +30 °C) the recommended setting is: position 2.

At optimal operating temperature (+20 to +25 °C) the recommended setting is: position 2/3.



Information



For use and for more information about an application, refer to the Mulcol documentation, local and international approvals.

See the **Mulcol Fire Protection app** for the correct application in combination with fire resistance, or use our **selector** at www.mulcol.com For professional use only.

19. Test Configuration

Introduction

The test configuration determines the application of plastic pipes. Before testing a pipeline type, the intended use of the pipeline must be considered. Where will it be used in practice? Standard EN 1366-3:2009 sets requirements in this regard. The end of the pipe must be capped or uncapped, based on this. See the test configuration in table 1 and 2.

In a test, the conditions to which the pipeline and the sealing system are exposed to are determined by asking whether one or both pipe ends are capped in practice. The pressure and flowrate of hot gases will be different in a pipe that is in contact with the outside air than in a capped pipe. It is important to ensure that the sealing system is tested under appropriate conditions.

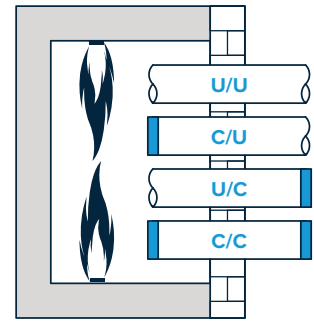

Table 1 - Test configuration plastic pipes

Test setup	Pipe end		Permitted use			
	In the oven	Outside the oven	U/U	C/U	U/C	C/C
U/U	Uncapped	Uncapped	✓	✓	✓	✓
C/U	Capped	Uncapped	✗	✓	✓	✓
U/C	Uncapped	Capped	✗	✗	✓	✓
C/C	Capped	Capped	✗	✗	✗	✓

Table 2 - Test configuration metal pipes

Test setup	Pipe end		Permitted use		
	In the oven	Outside the oven	U/C	C/U	C/C
U/C *	Uncapped	Capped	✓	✓	✓
C/U	Capped	Uncapped	✗	✓	✓
C/C	Capped	Capped	✗	✗	✓

* U/C tested and therefore U/U is covered

Plastic Pipes

Table H.1 shows a few examples of types of pipes and the intended use, where the end of the pipe is capped or uncapped. The table does not take all possible applications into account. The choice of whether to close the end or leave it open depends on a number of aspects: is the system under pressure and it is ventilated or unventilated? Consider the intended use of the pipe to determine whether it should be capped or left uncapped. If national regulations set different requirements than those contained in table H1, follow the regulations.

Table H.1 - Plastic Pipe Test Configuration per Application

Type of pipe	Pipe end		Test setup
	In the oven	Outside the oven	
Rainwater drainage	Uncapped	Uncapped	U/U
Sewage, Ventilated	Uncapped	Uncapped	U/U
Sewage, Unventilated	Uncapped	Capped	U/C
Gas pipe, drinking water pipe, hot water pipe	Uncapped	Capped	U/C

There is no application for a plastic pipe penetration with a test classification of C/U or C/C, according to table H.1 from EN 1366-3.

Metal Pipes

Metal pipes will normally be closed in the furnace as no open end is to be expected in the event of a fire, this due to the melting away of metal. Herewith is assumed that the suspension system remains in place. If the pipes are supported by a non fire resistant suspension system or are waste disposal shafts, the pipes are not sealed in the furnace, as shown in Table H.2.

Table H.2 - Test Configuration Metal Pipe by Application

Type of pipe	Construction		Test setup
	In the oven	Outside the oven	
Supported by a fire resistant ^a suspension	Capped	Uncapped	C/U
Supported by a non fire resistant suspension system	Uncapped	Capped	U/C
Shafts for waste disposal	Uncapped	Capped	U/C

^aconfirmed by testing or calculations (e.g. Eurocodes)

20. Building Element Properties

Flexible walls

The minimum wall thickness must be 100 mm and the wall must consist of steel or wooden posts* with at least 2 layers of cladding on both sides with a thickness of 12.5 mm. Can also be used with fire-stopping stone wool boards, 2 x 50 mm Multimastic FB1, maximum seal size: unlimited width x 1200 mm height (uninterrupted partition styles required, with a centre distance of up to 2400 mm).

Rigid walls

The minimum wall thickness is 100 mm and the wall must consist of concrete, aerated concrete or brickwork, with a minimum density of 650 kg/m³. Can also be used with fire-stopping stone wool, 2 x 50 mm Multimastic FB1, maximum seal size: unlimited width x 1200 mm height.

Rigid floors

The minimum floor thickness is 150 mm and the floor must consist of concrete or aerated concrete, with a minimum density of 650 kg/m³. Can also be used with fire-stopping stone wool boards, 2 x 50 mm Multimastic FB1, maximum seal size: 2400 x 1200 mm (w x h).

**There must be a minimum distance of 100 mm from each part of the conduit seal to a wooden post and the gap between the conduit seal and the post must be capped. The cavity between the conduit seal and the post must have at least 100 mm class A1 or A2 insulation (according to EN 13501-1).*

The support structure must be classified in accordance with EN 13501-2 for the specified fire resistance.

21. Available Documents

Technical documents

- ✓ Product Data Sheet (PDS)
- ✓ Technical Data Sheet (TDS)
- ✓ Safety Data Sheet (SDS)
- ✓ Installation Manual
- ✓ EC certificate
- ✓ Emission reports

Approvals

- ✓ Tested in accordance with EN 1366-3
- ✓ Classification in accordance with EN 13501-2
- ✓ Certified in accordance with EAD 350454-00-1104
- ✓ ETA report 17/0977
- ✓ Declaration of Performance (DoP)

The above documents are available from your Mulcol contact person or via www.mulcol.com



For help in finding the right fire-retardant finish for penetrations, see our **Multiselector** at www.mulcol.com or download the Mulcol Fire Protection App in the **App Store** (iOS) or **Google Play Store** (Android).



Mulcol International composed the technical data on this sheet with great care and reserves the right to change product properties without prior notification. The user of this data remains responsible at all times for the correct application thereof. In the event of a lack of clarity or doubt, we recommend consulting Mulcol International to confirm that this data complies with the required application.

MULCOL
INTERNATIONAL

